

The logo for HnuPHOTONICS features a stylized 'h' in red and 'nu' in blue, followed by 'PHOTONICS' in blue. The background of the top banner is light blue with a pattern of overlapping circles.

hnuPHOTONICS

The Power of Light

A large yellow rectangular box containing the company name and slogan in blue text.

HnuPhotronics

The Power of Light

**Presentation to
Maui Tech Ohana
February 6, 2008**

Presentation Outline

- **Company Background**
- **Products and Services**
- **Vision**
- **Business Development Approach**
- **Next Steps**
- **Community Support**
- **Q&A**

Company Background

- **Hnu Photonics, LLC 2nd Year Anniversary**
- **Hnu is a Maui based high tech company**
- **Intellectual Property**
 - Filed 10 U.S. patents; Filed 5 foreign patents; Filed 2 trademarks
- **Products**
 - 3 new products on the market 2007
 - 3 new products on the market 2008 (Goal)
- **Staff**
 - Year 1 2 full-time staff
 - Year 2 4 full-time, 2 part-time 2 MCC Interns / Co-Op
 - Year 3 10 full-time, 4 part-time 4 MCC interns / Co-Op

The Power of Light

$$E = MC^2 = h\nu$$

Light Energy =

Planck's Constant (6.626×10^{-34}) *
Frequency of Light

hν PHOTONICS

**Medical
Technologies**



**Energy
Technologies**



HNU·SOLAR
Harnessing the Power of Light

**Photonic
Technologies**

Defense

Commercial

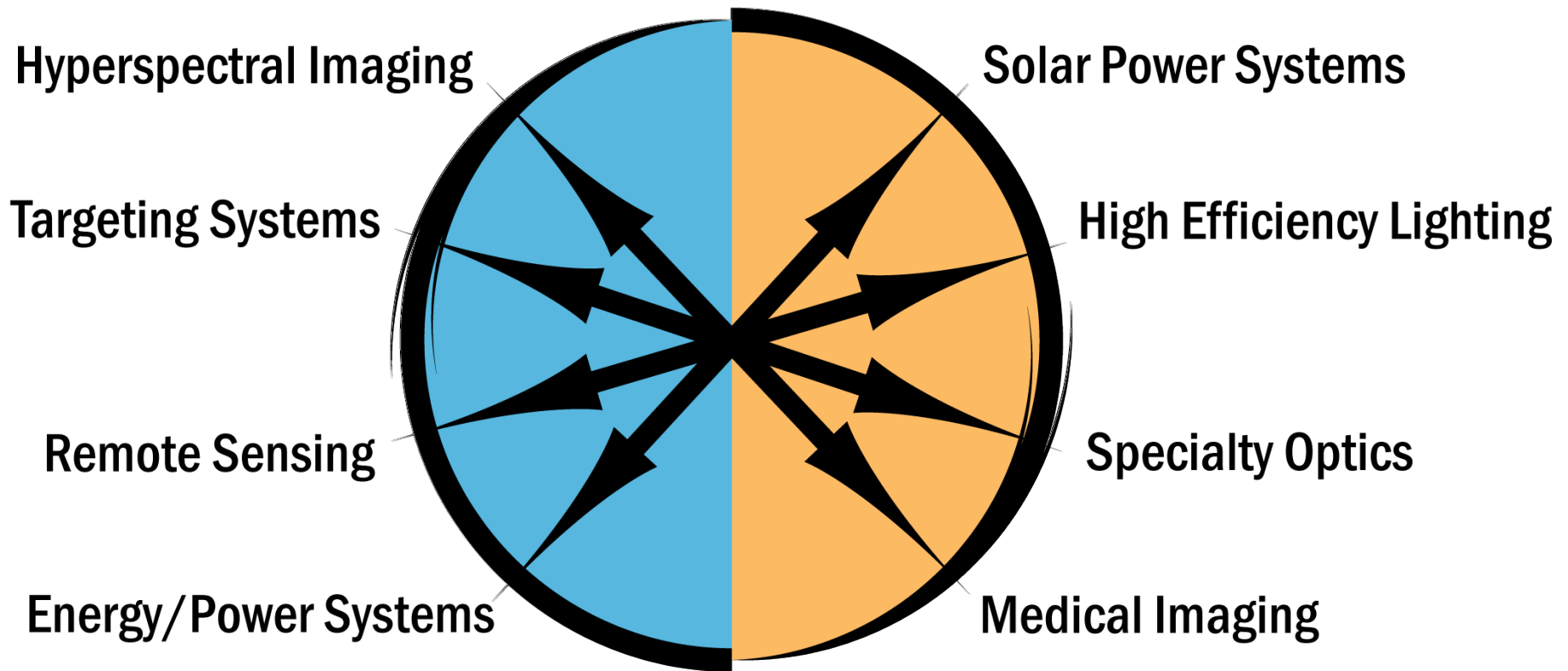

Unmanned Systems

Products & Services

• Products

- Telescopes
- Instruments
- Laser transceivers
- Spectrometers
- Medical Imaging
- Solar Panels
- High Efficiency LED Lighting
- Electro/Optical and Seismic Sensors
- Micro Power Supplies

• Services

- Optical Design & Fabrication
- Mechanical Design & Machining
- Coating
- Consulting
- Prototyping
- Product Development
- Solar Installation & Service

- Deployed 4D instrument on 1.2 meter telescope

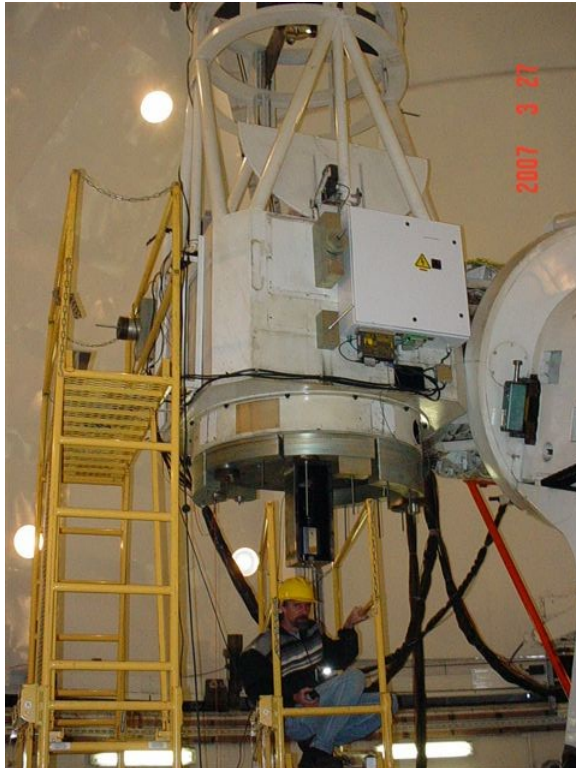

- Telescopes
 - 5 inch to 34 inch aperture



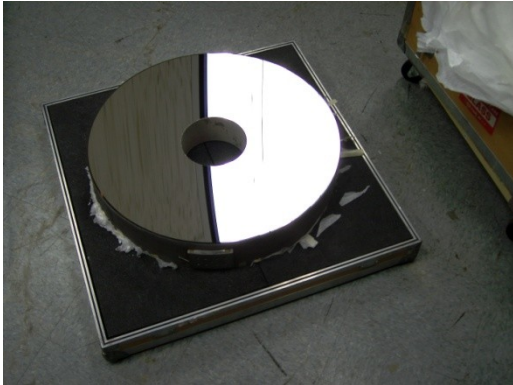

Optical Coatings

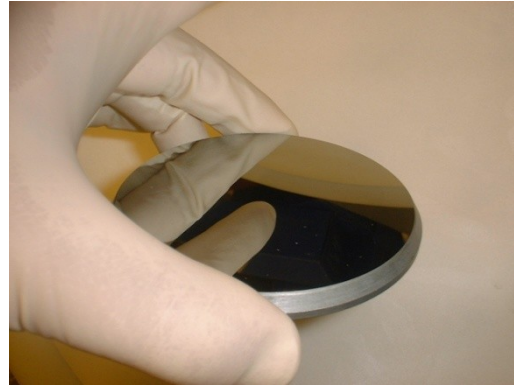

Infrared Optics

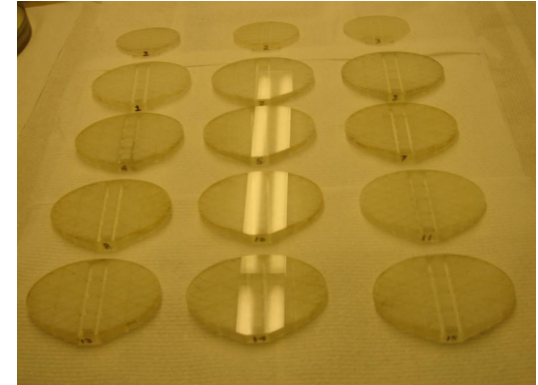

Laser Scan Mirrors

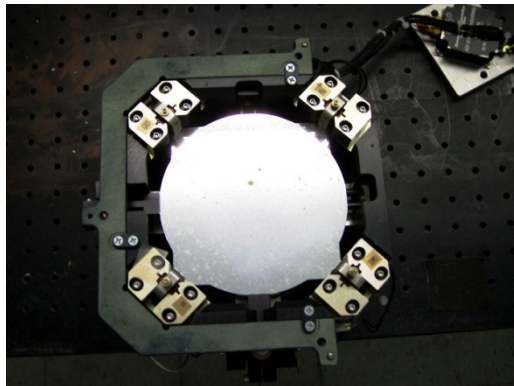

Optical Refurbishment



Lightweight Optics

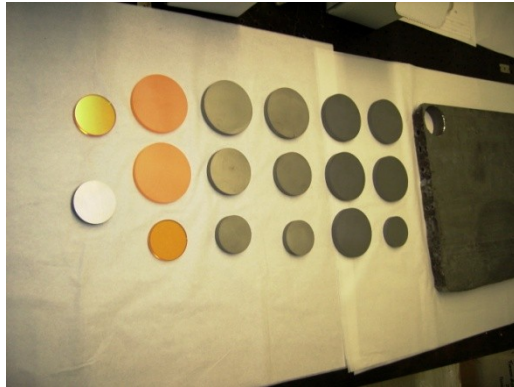

Raw material processing

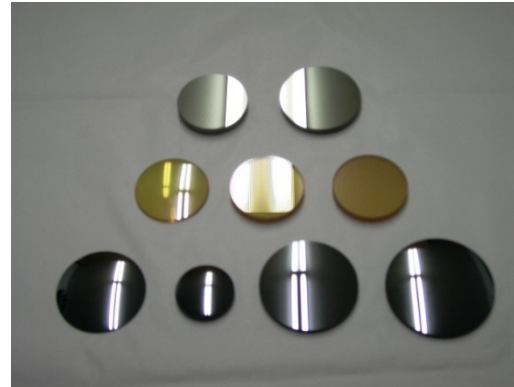

Infrared Optics

Silicon

Germanium

ZnSe

ZnS

CaF₂

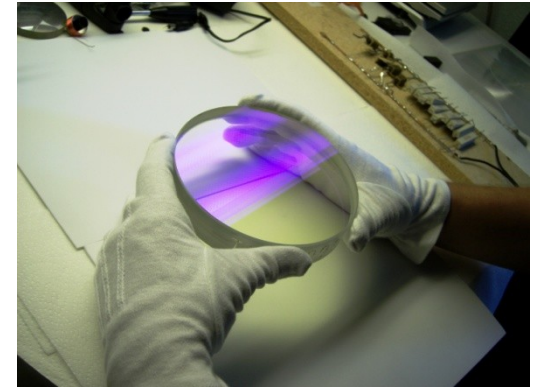

Optics for Free Electron Laser

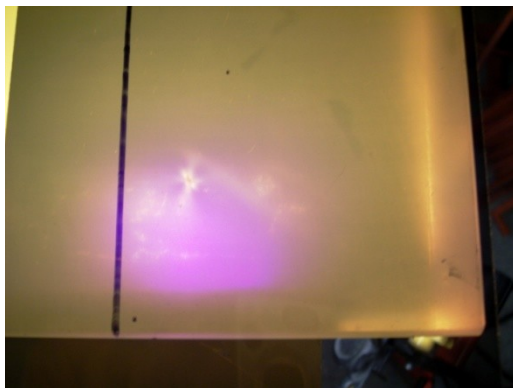

Materials Characterization

- Silicon Carbide Optics
 - Lightweight optics, High power laser optics

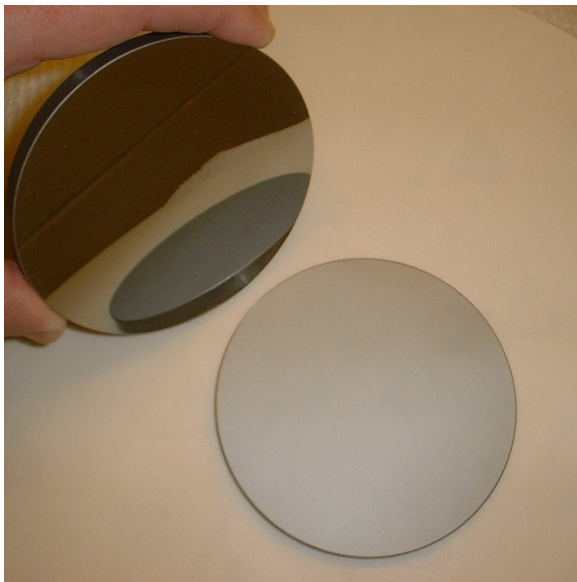

- Services
 - Refurbished 36” Laser Beam Director
 - Saved Govt. \$60,000

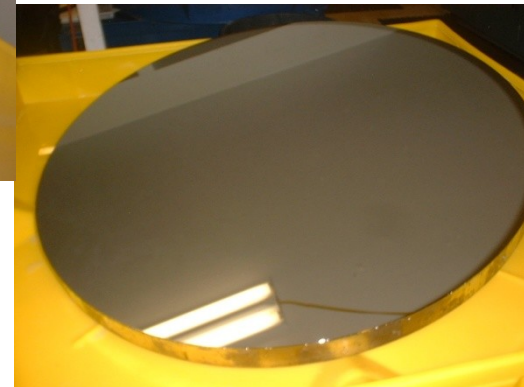

- Patent Pending Laser Instrument
 - Hnu is seeking licensing opportunity

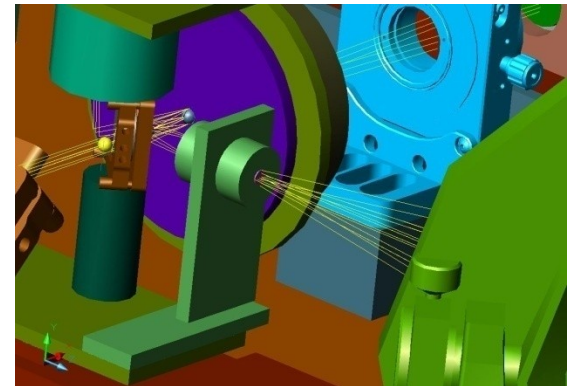
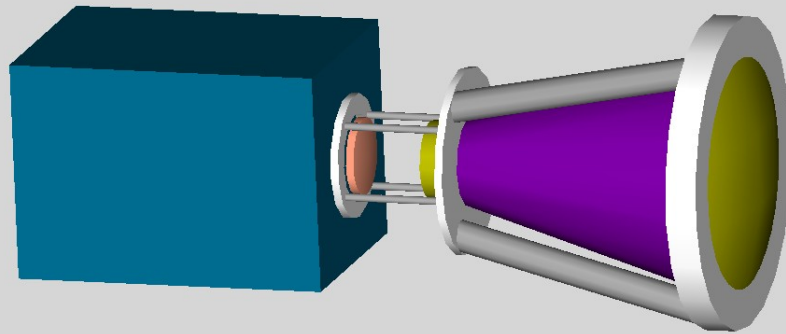



HNU.SOLAR
Harnessing the Power of Light

- **Solar Power Research**

- Commercializing state of the art solar PV technologies
- Cost-Efficient alternative to traditional energy
- Reduce costs for commercial and residential users





HNU.SOLAR
Harnessing the Power of Light

- **High efficiency solar modules**



- **High Efficiency Lighting**

- 85% more efficient than conventional lighting
- Commercial buildings, homes, hotels, restaurants



hV MEDICAL

- Laser Scanning Micro Optical Technology
- Real Time Lab
- “Instant” Biopsy
- High Power Instrumentation available to hospitals; clinics; universities world-wide
- Making conventional laboratories obsolete

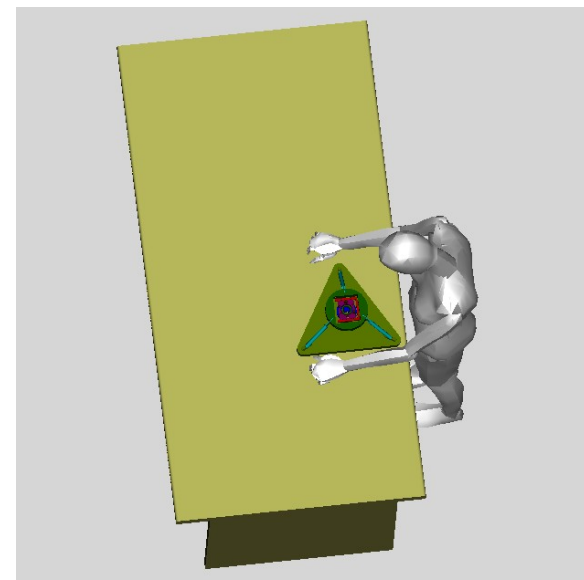
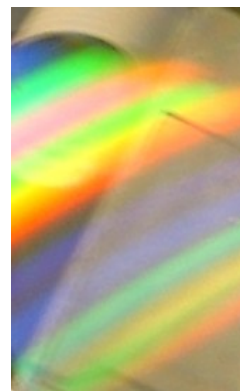

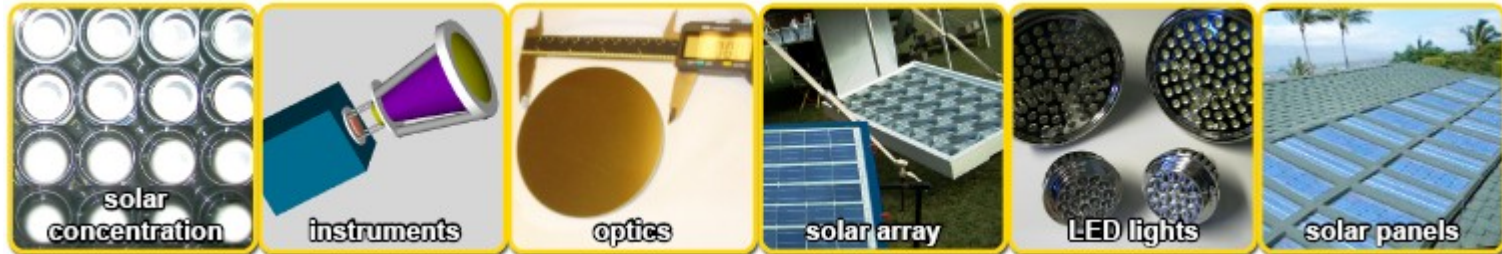

HnuPhotonics Vision

- **Ideas Factory**
- **Invention Laboratory**
- **Manufacturing Facility**

Development Approach

Concept → Prototype → Product

Brainstorm → develop concept → initial design →
fabricate alpha prototype → design revision →
beta prototype → product → commercialization

2008 Next Steps

- **2008 Goal:** Largest optical fabrication and instrument prototyping facility in Hawaii
- **Facility/Expansion :** Expanding into 6,000 sq-ft
 - Acquiring TORC; Relocating Tucson's core optical capability to Hawaii
- **Commercial Roll-out:**
 - Solar Power; High Efficiency Lighting (LED)
 - Medical Imaging
- **Defense Applications:** Near Space; Missile Defense; Remote/Covert Sensing
- **MCC Solar Initiative**

Goals for Future:

- State of the art manufacturing
- Keep Defense Funding for Technology on-island
- Grow global commercial markets for imaging, energy, and medical applications
- Supports local economy and High tech jobs

Community Support:

Support to Hawaii's Military and University

- **Optics, Mechanics, Instruments**
 - UH – Free Electron Laser
 - IFA – PanSTARRS
 - Navy; Air Force; Army
 - Defense contractors
- **MCC Solar Initiative**

Contact Information:

Dan O'Connell

HnuPhotonics

851 Eha Street, Wailuku, HI

(808) 244-7800

doconnell@hnuphotonic.com

www.hnuphotonics.com

www.hnusolar.com

